

Product change notification (PCN)

Title / short description	Change in ST 2,5 housing
Affected article category	Terminal blocks
Change category	Form and appearance
Change number	PBE160082-00

Purpose/objective of the change

Improvement in housing stability under special ambient conditions

Detailed description of the change

Bracing of housing

Identifying characteristics

New ribbing arrangement

Start of Production (SOP)	-	Last Time Delivery (LTD)	-
Effective date (EOP)	2020-09-01	End of Service (EOSR)	-
End of Sales (EOS)	-		

Short-term change (< 6 months) or discontinuation (< 12 months), due to:

- | | | |
|---|--|--|
| <input type="checkbox"/> Software / Firmware Bugfix | <input type="checkbox"/> Short-term delivery stop by supplier | <input type="checkbox"/> Short-term recall by supplier |
| <input type="checkbox"/> Force majeure | <input checked="" type="checkbox"/> Product improvement with customer benefits | |
| <input type="checkbox"/> Others | | |

Attachments

- PBE160082 ST 25 GEH -PxCN_1.pptx
- Material_list.csv
- PCN-PBE160082-00 Change of ST 2,5 Housing_DE
- PCN-PBE160082-00 Change in ST 2,5 housing_EN

Material list

Item	Article Type	Hardware old	Firmware new	Item	Substitute item Type
3031212	ST 2,5	01	01		
3037122	ST 2,5 BK	01	01		
3035360	ST 2,5 BN	01	01		
3031225	ST 2,5 BU	01	01		
3037106	ST 2,5 GN	01	01		
3037070	ST 2,5 OG	01	01		
3037096	ST 2,5 RD	01	01		
3037119	ST 2,5 WH	01	01		
3037083	ST 2,5 YE	01	01		
3031238	ST 2,5-PE	02	02		

ST 2,5 GEH

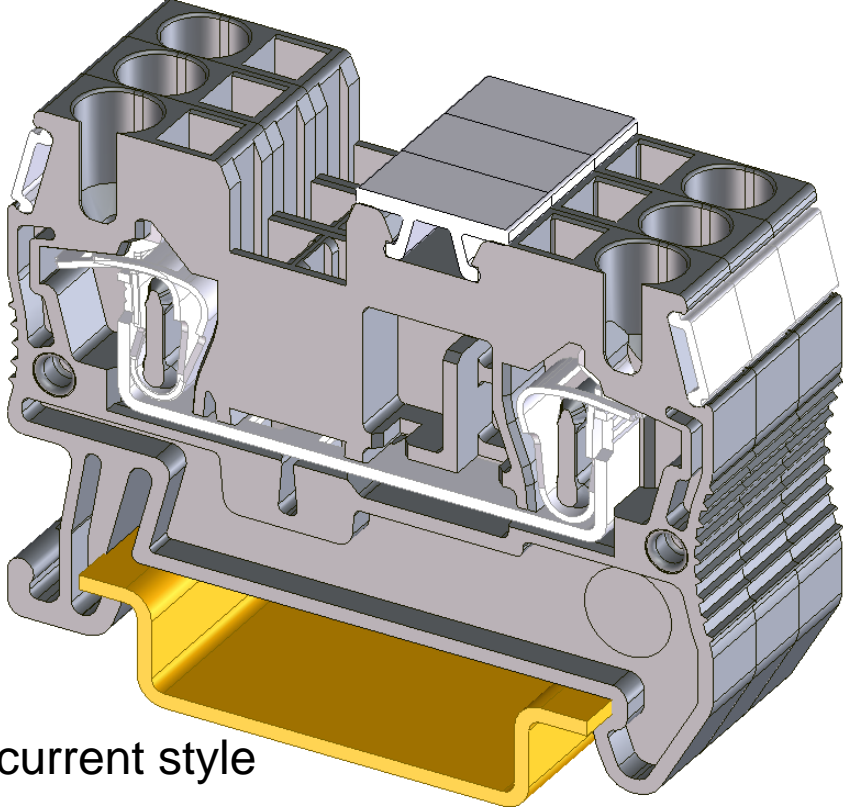

current style

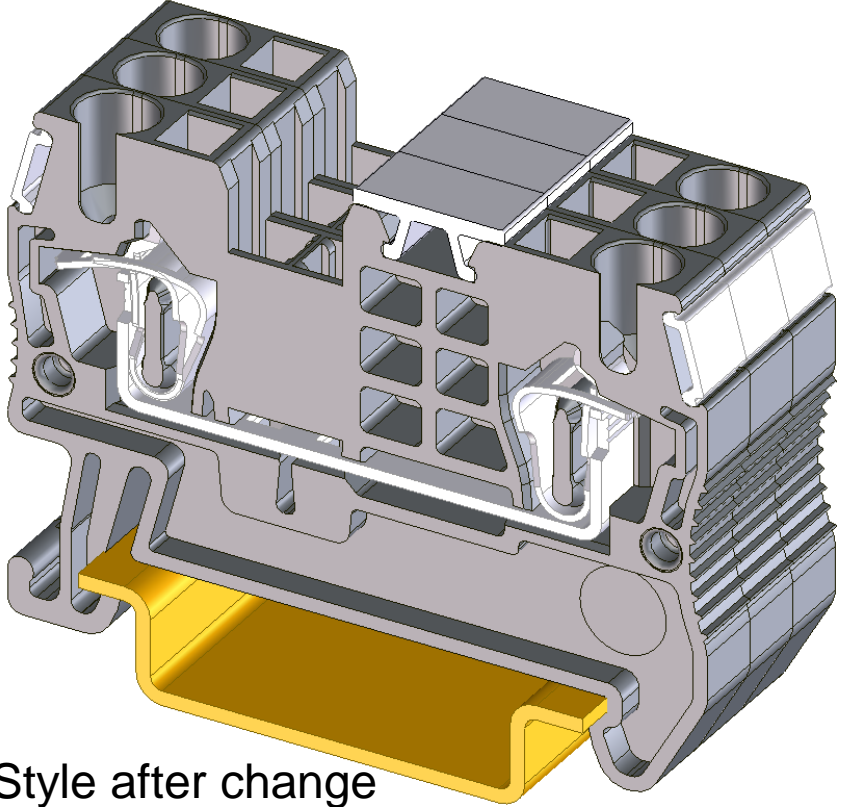

Style after change

both styles are valid

Change of ST 2,5-Housing

ST 2,5 GEH

- Due to capacity expansion in China a new injection mould is required
- A new design in the moulding will be realized
- The new design will improve the stability of the housing for extrem conditions
- In other production locations, the old design will be valid till a maintenance of the moulding tool will be necessary
- Over the time all other production location will get successively the new design
- technical rates and dimensions remain the same
- Mixing of inventory is possible

3031212	ST 2,5
3037122	ST 2,5 BK
3035360	ST 2,5 BN
3031225	ST 2,5 BU
3037106	ST 2,5 GN
3037070	ST 2,5 OG
3037096	ST 2,5 RD
3037119	ST 2,5 WH
3037083	ST 2,5 YE
3031238	ST 2,5-PE